

Biaxial Warp Knitting Machine 双轴向经编机

RSM3/1(186"/215"/247") E24 Interlining Warp Knitting Machine

Main Program Parameter

Gauge:E24

Working Width:186",215",247"

Bar Number:2 ground bars, 1 warp insertion bar

Speed:20-1200rpm (Depends On Pattern And Material)

Shogging Manner:Pattern disc

Let-off Manner: EBA System

Take-up System:EWA System

Needle Type:Compound Needle

Main power:7.5KW(186"),11 KW(215",247")

2: Bar arrangement:

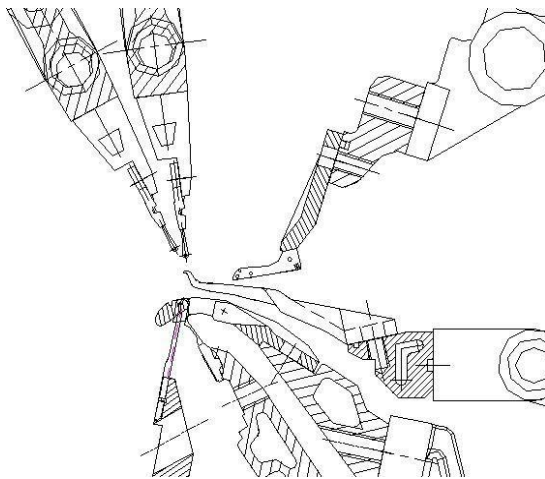

3: Machine size:

